

PWM+PFM CONTROLLER WITH BUILT-IN HIGH VOLTAGE MOSFET

1.DESCRPTION

SDH8634 is current mode PWM+PFM controller used for SMPS, with built-in high voltage MOSFET, high-voltage startup constant current source, and external sensing resistor.

SDH8634 has a built-in high-voltage startup constant current source, features low standby power dissipation (<30mW) and multi-mode control. At heavy load condition, it works in PWM mode. At light load condition, it works in PFM mode to improve the conversion efficiency. At no load, it enters burst mode to reduce the standby power dissipation.

SDH8634 integrates switching frequency jitter to achieve low EMI. Built-in peak current compensation circuit makes the limit output power consistent even with different input AC voltages. Built-in soft startup reduces the transformer stress during power-on process to avoid transformer saturation.

SDH8634 integrates comprehensive exceptional protections including leading edge blanking (LEB), cycle-by-cycle peak current limit, VCC overvoltage protection(OVP), output overload protection(OLP) and over-temperature protection(OTP) etc.

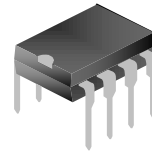

DIP-8-300-2.54

3.APPLICATIONS

- ◆ SMPS

2.FEATURES

- ◆ High-voltage startup
- ◆ Low standby power dissipation<30mW
- ◆ Multi-mode control
- ◆ Switching frequency jitter
- ◆ Peak current compensation
- ◆ Soft startup
- ◆ Leading edge blanking(LEB)
- ◆ Cycle-by-cycle current limit
- ◆ VCC overvoltage protection(OVP)
- ◆ Output overload protection(OLP)
- ◆ Over-temperature protection(OTP)

4.ORDERING INFORMATION

Part No.	Package	Marking	Hazardous Substance Control	Packing Type
SDH8634	DIP-8-300-2.54	SDH8634	Halogen free	Tube

5. BLOCK DIAGRAM

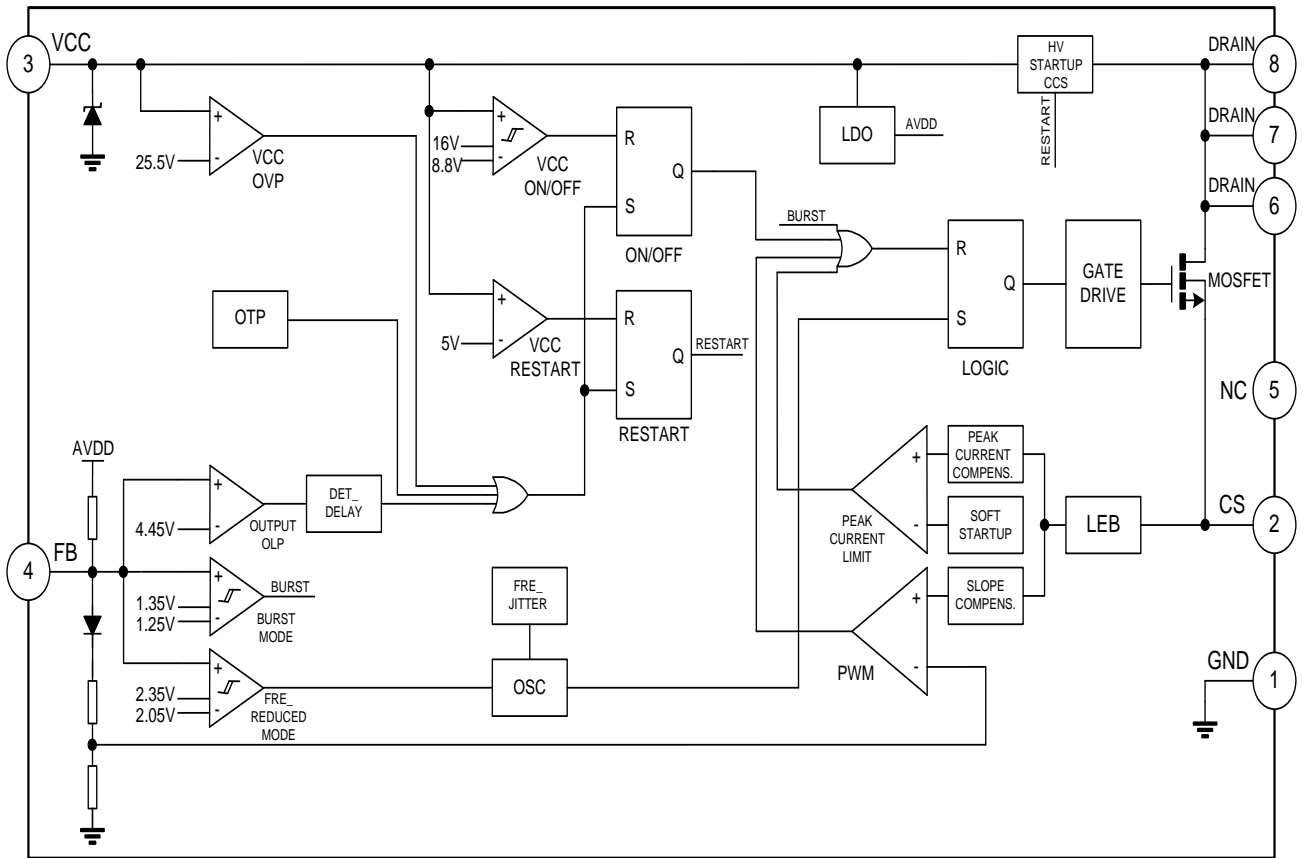

6. PIN CONFIGURATION

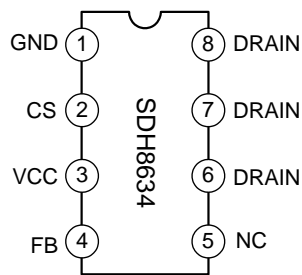

7.TYPICAL APPLICATION CIRCUIT

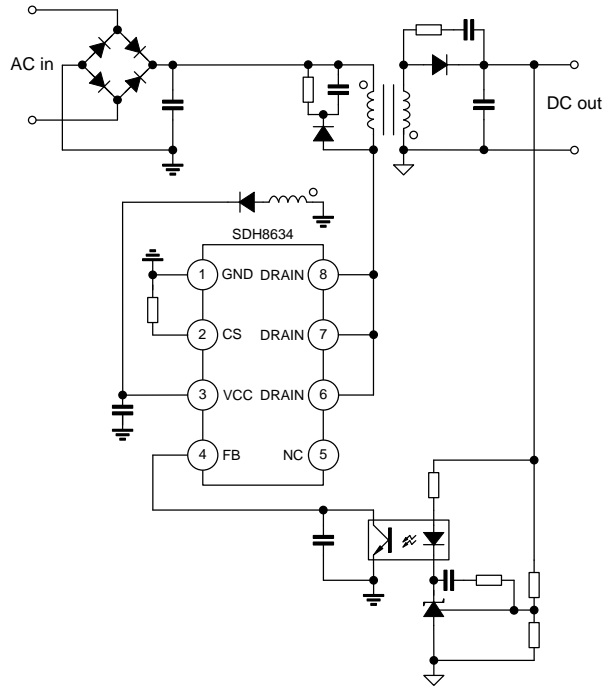

8.PACKAGE OUTLINE

DIP-8-300-2.54

UNIT: mm

SYMBOL	MILLIMETER		
	MIN	NOM	MAX
A	—	—	4.10
A1	0.50	—	—
A2	2.90	3.30	3.40
b	0.38	0.46	0.55
B1	1.22	1.52	1.82
c	0.20	0.25	0.32
D	9.00	9.40	9.80
E	7.62	7.87	8.26
E1	6.10	6.35	6.60
e	2.54BSC		
eA	7.62BSC		
eB	7.62	—	9.30
eC	0	—	1.52
L	3.00	—	—

Important notice :

1. Silan reserves the right to make changes of this instruction without notice.
2. Customers should obtain the latest relevant information when purchasing and should verify whether such information is latest and complete. Please read this instruction and application manual and related materials carefully before using products, including the circuit operation precautions, etc.
3. The products belong to consumer electronic products. Silan does not give any warranties as to the suitability of the Silan's product for any specific use. The design intent, design definition and design of the product are not intended for application (the application stated in this instruction includes use, etc.) in transportation equipment, medical equipment, life-saving equipment, aerospace equipment, , non-civil equipment or non-civil use, etc. (the equipment stated in this instruction includes systems, devices, etc., all referred to as equipment).The product should not be used in any equipment or system whose manufacture, use or sale is prohibited under any applicable laws or regulations ("unintended use"). If the product is used for unintended use, therefore the full risks of such products application are borne by the customer and Silan assumes no liability for the product used for the unintended use. If the customer intends to use the Silan's product in a application where malfunction or failure can be reasonably be expected to result in personal injury, or serious property, or environment damage, the customer shall make adequate assessment, testing and verification, and Silan shall not be liable for such applications.
4. The application of the product described in this instruction, the application manual of the product and related materials is for illustrative purposes only, and Silan makes no warranty that such application can be used directly without further testing, verification or modification. Silan is not responsible for any assistance in product application or customers' product design. Customer shall be responsible for the application of Silan's products and the design, manufacture and use of customers' products using Silan's products (in this document, "use products", "apply Silan's products", "product application" and "customers' products using Silan's products" are synonymous). It is the sole responsibility of the customer to take the following actions: 1) Verify and determine whether Silan's products are suitable for the customers' applications and customers' products; 2) All applicable standards of the customers' industry shall be complied with and fully tested and verified when applying Silan's product or using Silan's product to develop and design customers' products; 3) Although Silan is constantly committed to improve product's quality and reliability, semiconductor products have possibility to malfunction or fail in various application environments. Customers are responsible for complying with safety standards and for providing adequate designs and safeguards for customers' products using Silan's product to minimize risks and avoid situations in which a malfunction or failure could cause bodily injury or damage to property; 4) When using the products, please do not exceed the maximum rating of the products, Stress above one or more limiting values will cause damage to the product and the equipment or affect the reliability to the equipment (customers' product); 5) Ensure customers' product using Silan's product are designed, manufactured and used in full compliance with all applicable standards, safety standards and other requirements of the customers' industry. The parameters stated in this instruction may and do vary in different applications, actual performance may vary over time. Customers must use the products within their effective static storage period, please contact Silan sales or Silan customer service support and sales management department if there is any questions about the effective static storage period, Silan does not assume any responsibility if the product has exceeded the static storage period when it is used.
5. Do not disassemble, reverse-engineer, alter, modify, decompile or copy product, without Silan's prior written consent.
6. Please identify Silan's trademark when purchasing our product. Please contact us if there is any question. Our products are not sold through TAOBAO or any other third-party e-commerce platforms. If customers purchase from such platforms, please contact us in writing before purchasing to confirm whether the product is authentic and original from Silan.
7. Please use and apply product in compliance with all applicable laws and regulations, including but not limited to trade control regulations etc. The product is civil electronic product, please do not use it in non-civil fields.
8. Product promotion is endless, our company will wholeheartedly provide customers with better products!
9. Website: <http://www.silan.com.cn>